

SPEED QUEEN MULTI-HOUSING

QUANTUM® GOLD COIN DROP INSTALLED, PREP FOR COIN, PREP FOR CARD COMMERCIAL FRONT CONTROL FRONT LOAD WASHER

Built for Reliable Performance

Engineered and built like no other, the Speed Queen front load washer is designed to be everything people thought a washer couldn't be, beginning with its revolutionary suspension and sensing technology. This groundbreaking innovation manages and redistributes out-of-balance loads to deliver uninterrupted cycles, virtually eliminate vibration and operate so quietly neighboring residents won't even know it's running. It also touts an incredible 440 G-Force extraction speed to maximize moisture removal, reduce dry times and minimize utility costs. And as if that's not game-changing enough, this smooth-running, laundry-optimizing machine delivers increased water efficiency. It's everything you never knew it could be. Front load products have met every design standard to be 100% ADA compliant.

- Revolutionary balancing technology
- Industry leading 1200 RPM spin speed exerts 440 G-force extraction
- Integrated meter case
- Extra-wide 15.5" door opening and 180° door swing
- Rugged suspension system
- Easy-to-read digital display
- Large capacity coin box standard
- Multi-level vend pricing
- Individual cycle modifier keys
- Durable stainless steel tub standard
- Four-compartment soap dispenser
- Wash Alert™ with Service Alert capable



 ENERGY STAR® Certified Washer

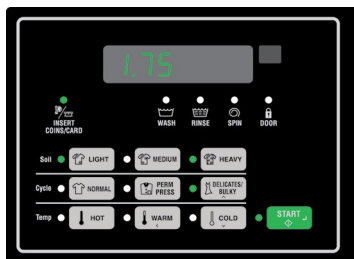

Cutting edge Quantum control system from Speed Queen gives you the freedom to manage laundry your way and the power to achieve unmatched levels of revenue. This revolutionary technology provides users with more cycle choices than ever, offers unprecedented options to help lower operating costs and incorporates tools and options to increase revenue.

SPECIFICATIONS

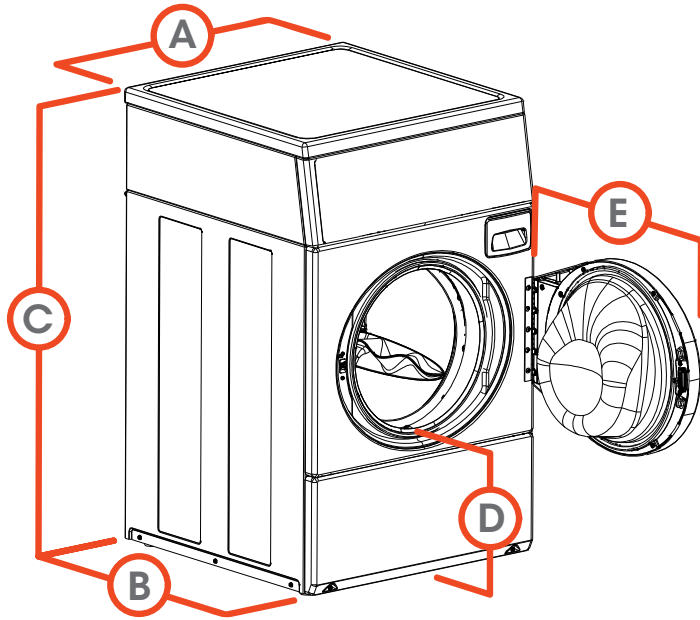

COMMERCIAL FRONT CONTROL FRONT LOAD WASHER

MODEL - see below for all models and activation available	
CONTROL OPTION	Quantum Gold
COLOR	White
CAPACITY - lb (kg)	21.5 (9.5)
OVERALL WIDTH - in (mm)	26.875 (683)
OVERALL DEPTH - in (mm)	27.73 (704)
OVERALL HEIGHT - in (mm)	44.34 (1126)
CYLINDER VOLUME - cu. ft. (liters)	3.42 (96.8)
SPIN SPEED G-FORCE (RPM)	440 (1200)
MOTOR SIZE - HP (kw)	0.9 (0.67)
WATER CONSUMPTION PER CYCLE - g (liter)	11.7 (44.3)
WF (WATER FACTOR) - gal/ft ³ (liters/liter/cycle)	3.8 (0.52)
MEF (Modified Energy Factor) ft ³ /kWh/cycle (Liters/kWh/cycle)	2.98 (84.48)
AVAILABLE WATER TEMPERATURES	Hot, Warm, Cold
AVAILABLE CYCLES	Normal, Perm Press, Delicates/Bulky
ELECTRICAL REQUIREMENTS (v/Hz/Ph-Amp)	120/60/1 - 15 Amp
WATER PRESSURE - p.s.i. (bar)	20-120 (1.4/8.3)
CYLINDER FINISH	Stainless Steel
NET WEIGHT - lb (kg)	260 (118)
SHIPPING WEIGHT - lb (kg)	270 (122.5)
SHIPPING DIMENSIONS APPROX. - in (mm)	Width 34 (864)
	Depth 30 (762)
	Height 44.5 (1130)
AGENCY APPROVALS	cULus



A.	OVERALL WIDTH - in (mm)	26.875 (683)
B.	OVERALL DEPTH - in (mm)	27.73 (704)
C.	OVERALL HEIGHT - in (mm)	44.34 (1126)
D.	FLOOR TO DOOR OPENING -in (mm)	14.6 in. (371)*
E.	DOOR SWING - in (mm)	24 in. (610)

* For ADA compliance turn legs out from base 0.5 inches

MODELS	DRAIN	ACTIVATION
SFNNCASP113TW01	Pump	Coin Drop Installed 
SFNNCASG113TW01	Gravity	
SFNNCAJP113TW01+	Pump	
SFNNXASP113TW01	Pump	Prep for Coin 
SFNNXASG113TW01	Gravity	
SFNNYASP113TW01	Pump	Prep for Card 
SFNWYASP113TW01*	Pump	
SFNNYAJP113TW01+	Pump	
SFNNYASG113TW01	Gravity	

+ Supply Injection

* Wireless Network Board Factory Installed

For the most accurate information, the installation guide should be used for all design and construction purposes. Due to continuous product improvements, design and specifications subject to change without notice. The quality management system of Alliance Laundry Systems' Ripon facility has been registered to ISO 9001:2008.